

AGES 4+

FurReal  
friends



# Furry Frenzies™



 **x2**  
1.5V AAA  
LR03 size  
**ALKALINE  
BATTERIES  
REQUIRED  
NOT INCLUDED**

Phillips/cross head  
screwdriver  
(not included)  
needed to insert  
batteries.

**Adult assembly required.**

**Cruisin' Carrier™**



**CAUTION:**

Hair entanglement may result if child's hair comes in contact with moving parts of toy. Adult supervision is required.



**WARNING:**

CHOKING HAZARD—Small parts.  
Not for children under 3 years.

Just like a real animal, it's normal for your FURRY FRENZIES toy to shed a little when you groom it.

**INCLUDES**

**Playset**

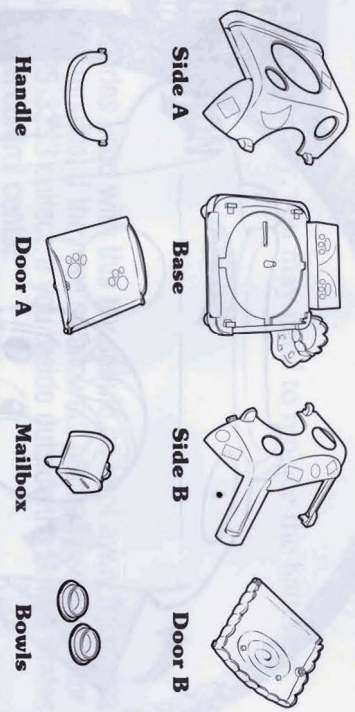

**Labels/Accessories**

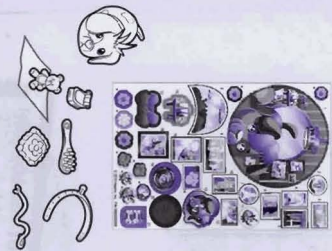

**PLAYSET ASSEMBLY**

Assembling the CRUISIN' CARRIER playset is easy! Just follow these steps:

**1**

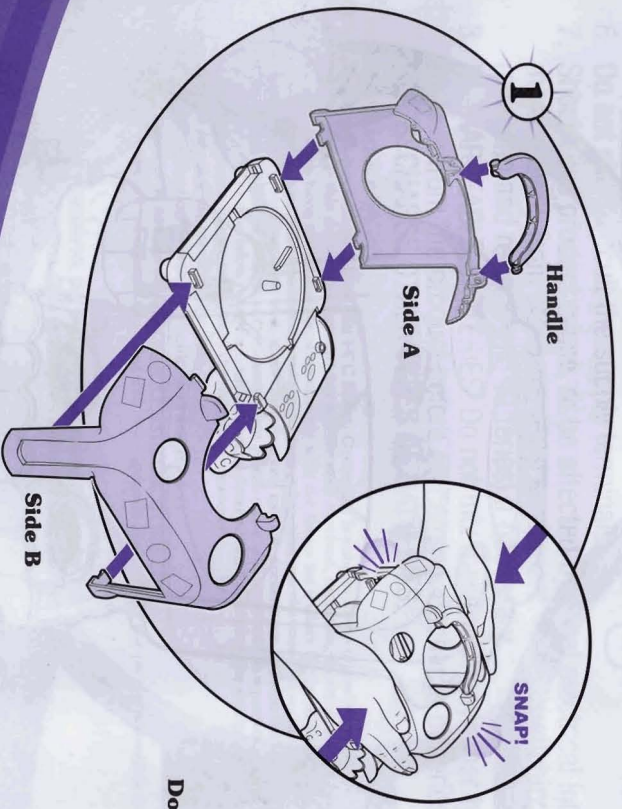

**2**

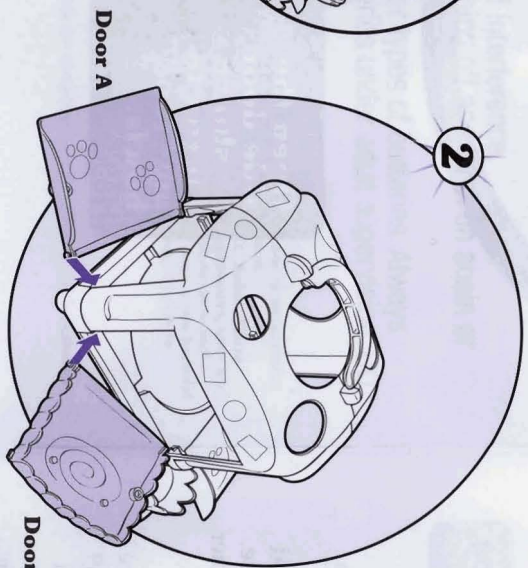

**3**

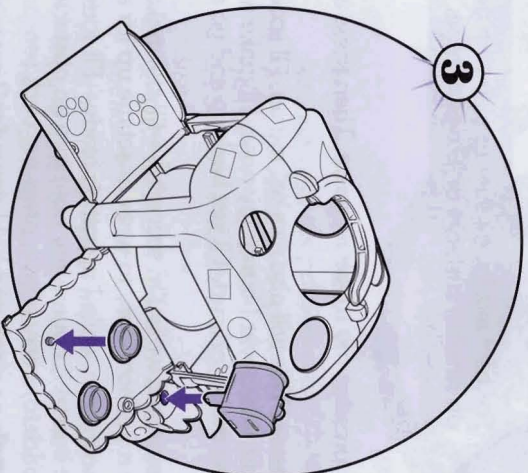

# APPLYING LABELS

Now you're ready to add sticker labels!

**NOTE:** Labels marked with \* are for free play.



## Front View

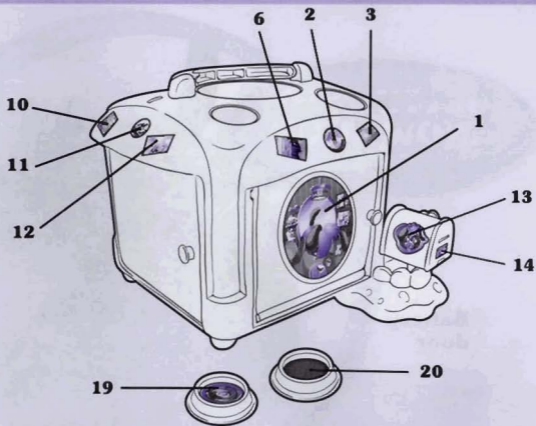

## Rear View

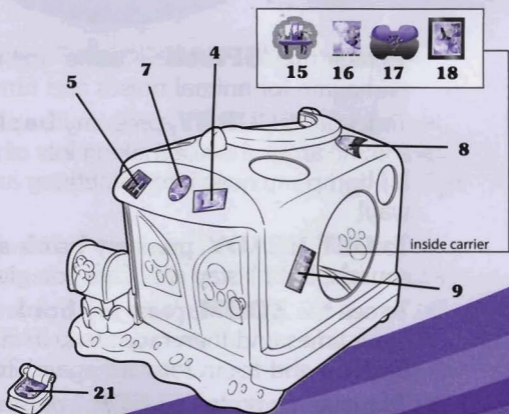

## TO INSTALL BATTERIES

Use a Phillips/cross head screwdriver (not included) to loosen screw in battery compartment cover (screw remains attached to cover). Remove cover. Remove and discard old batteries. Replace with **fresh** 2 x 1.5V "AAA" or LR03 size alkaline batteries. Replace cover and tighten screw.

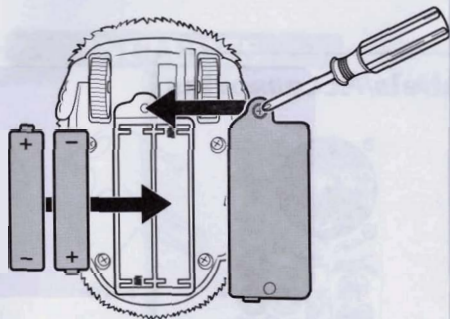

## GETTING TO KNOW YOUR PET



**Back sensor**

A sensor is a part of the toy that responds to your touch!

**Battery door**

**Nose sensor**

Type and color of pet may vary.

For best results, be sure to play with your pet on smooth surfaces or low-pile carpeting.

- To hear me "**SPEAK**," "wake" me up by pressing my **nose sensor**. Then press again and again for animal noises and funny sounds!
- To let me **SCURRY**, press my **back sensor**. This will also "wake" me up. I'll scoot and spin all around while making lots of sounds! Whenever I bump my nose, I'll make a noise. If I bump my nose into something and can't move forward, I'll just back up and go another way!
- To **GET READY**, press my **back sensor** again while I'm scurrying—I'll still make sounds, but I'll stay still. Can you give me a fun accessory to wear or set me up for a race?
- To see me **ZOOM**, press my **back sensor** again while I'm getting ready—I'll sound off three times and then race away in straight bursts! If I bump my nose into an obstacle, I'll back up and zoom forward again! To go back to scurry mode, press my back sensor again.
- To make me go to "**SLEEP**," press my **back sensor** and hold down for 2 seconds. I'll make a sleepy sound and shut off.

**NOTE:** Your pet will go for up to 2 minutes in scurry mode, and for up to 30 seconds in get ready and zoom modes. If the back sensor is not pressed again within those times, your pet will go to "sleep."

LET'S PLAY!



Let me run around inside, and take me with you! This door closes behind me when I run in.

Open the side door as shown—I'll run to my "food" bowls.

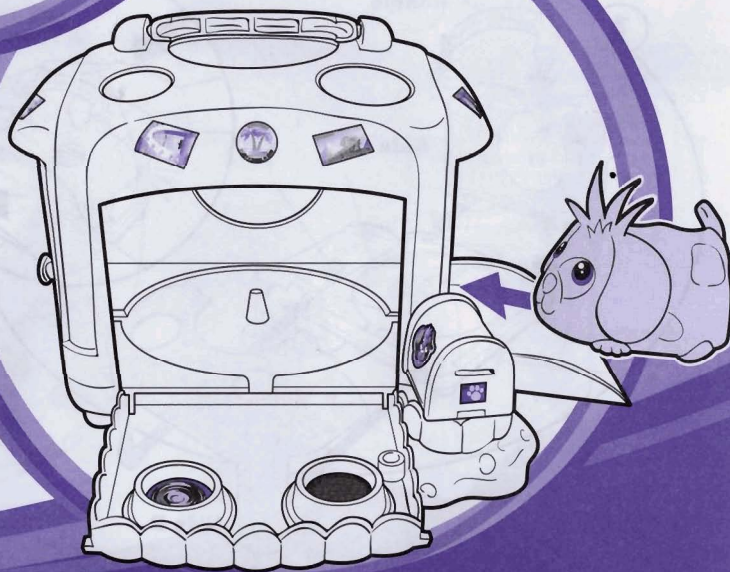

## CLEANING YOUR PET

Gently brush your pet's fur with a cloth or soft brush to loosen any dirt. You can use a slightly damp cloth to remove stains, but don't get it wet or use any cleaners on your pet.

## TROUBLESHOOTING

If your pet doesn't seem to respond properly, you may need to replace the batteries.

## IMPORTANT: BATTERY INFORMATION



### CAUTION:

1. As with all small batteries, the batteries used with this toy should be kept away from small children who still put things in their mouths. If they are swallowed, promptly see a doctor and have the doctor phone (202) 625-3333 collect. If you reside outside the United States, have the doctor call your local poison control center.
2. Always follow the instructions carefully. Use only batteries specified and be sure to insert them correctly by matching the + and - polarity markings.
3. Do not mix old batteries and new batteries or standard (carbon-zinc) with alkaline batteries.
4. Remove exhausted or dead batteries from the product.
5. Remove batteries if product is not to be played with for a long time.
6. Do not short-circuit the supply terminals.
7. Should this product cause, or be affected by, local electrical interference, move it away from other electrical equipment. Reset (switching off and back on again or removing and re-inserting batteries) if necessary.
8. **RECHARGEABLE BATTERIES:** Do not mix these with any other types of batteries. Always remove from the product before recharging. Recharge batteries under adult supervision. **DO NOT RECHARGE OTHER TYPES OF BATTERIES.**

### FCC STATEMENT

This device complies with part 15 of the FCC Rules. Operation is subject to the following two conditions: (1) This device may not cause harmful interference, and (2) this device must accept any interference received, including interference that may cause undesired operation.

This equipment has been tested and found to comply with the limits for a Class B digital device, pursuant to part 15 of the FCC Rules. These limits are designed to provide reasonable protection against harmful interference in a residential installation. This equipment generates, uses and can radiate radio frequency energy, and, if not installed and used in accordance with the instructions, may cause harmful interference to radio communications. However, there is no guarantee that interference will not occur in a particular installation. If this equipment does cause harmful interference to radio or television reception, which can be determined by turning the equipment off and on, the user is encouraged to try to correct the interference by one or more of the following measures:

- Reorient or relocate the receiving antenna.
- Increase the separation between the equipment and receiver.
- Consult the dealer or an experienced radio/TV technician for help.

**CAUTION:** Changes or modifications to this unit not expressly approved by the party responsible for compliance could void the user's authority to operate the equipment.



**NOTE TO UK CONSUMERS:** This product and its batteries must be disposed of separately at your local waste recycling centre. Do not dispose of in your household waste bin.



Product and colors may vary.

© 2010 Hasbro. All Rights Reserved.

TM & © denote U.S. Trademarks.

24483/20722 Asst.

PN 704607000

**FurRealFriends.com**

Questions? Call 1-800-844-3733